

VertiClip® SL w/ 3" slots

Exterior Head of Wall

Material Composition

ASTM A1003/A1003M Structural Grade 50 (340) Type H, ST50H (ST340H): 50ksi (340MPa) minimum yield strength, 65ksi (450MPa) minimum tensile strength, 68mil minimum thickness (14 gauge, 0.0713" design thickness) with ASTM A653/A653M G90 (Z275) hot dipped galvanized coating.

The attachment of VertiClip SL w/ 3" slots to the primary structure may be made with PAFs, screw/bolt anchors or weld and is dependent up the base material (steel or concrete) and the design configuration.

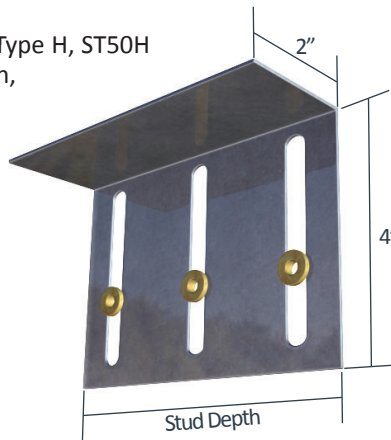

US Patents #5,467,566 & #5,906,080

VertiClip SL w/ 3" Deflection Allowable (Unfactored) Loads¹

VertiClip® SL w/ 3" Deflection, Recommended Allowable Load (lbs): F1 & F2							
	F1 Load Direction			F2 Load Direction			
	SL600, s3lg,b2d		SL362, s3lg,b2d	SL600, s3lg,b2d		SL800, s3lg,b2d	
Screw Patterns with #12 Screws	w/2 #12 Screws	w/3 #12 Screws	w/2 #12 Screws	w/2 #12 Screws	w/3 #12 Screws	w/2 #12 Screws	w/3 #12 Screws
33mil (20ga), 33ksi Stud	190	277	376	376	564	376	564
33mil (20ga), 50ksi Stud	276	277	544	544	816	544	816
43mil (18ga), 33ksi Stud	248	277	560	560	840	560	840
43mil (18ga), 50ksi Stud	277	277	617	810	1,215	810	1,215
54mil (16ga), 33ksi Stud	277	277	617	788	1,182	788	1,182
54mil (16ga), 50ksi Stud	277	277	617	1,138	1,571	1,138	1,707
68mil (14ga), 50ksi Stud	277	277	617	1,434	1,571	1,434	1,915
97mil (12ga), 50ksi Stud	277	277	617	1,434	1,571	1,434	1,915
Max Allowable Clip Load	277		617	1,571		1,915	

Notes:

- VertiClip SL s3lg, b2d is designed to support horizontal loads, and should not be used in axial load-bearing walls.
- Allowable loads have not been increased for wind, seismic, or other factors.
- Meets IBC criteria for light steel framing. Factor of Safety calculated according to ICC-ES AC261 and Chapter K of AISI S100.
- Tests performed with with bushings centered in the 3" slots.
- The standard bushing placement is 2" from the top of the slot an allows the structure to settle ½" prior to typical service.
- Total vertical deflection of up to 3" (2" up and 1" down).
- #12 screws are provided with each step bushing for attachment to the stud web.
- Fasten within ¼" of the angle heel (centerline of the 1 ½" leg) to minimize eccentric load transfer.
- For LRFD strengths contact TSN technical services.

Load Direction

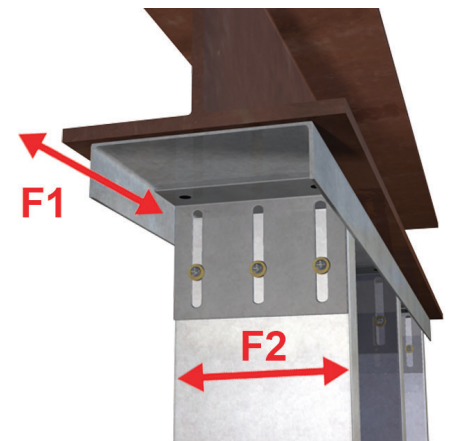

Nomenclature

VertiClip SL with 3" deflection is designated by type (SL), followed by stud depth in inches multiplied by 100, slot length (s "length in inches" lg), and bushing placement (b "distance from top slot in inches" d).

Example: 6" deep stud, 3" slot, bushings 2" down from top of slot
Designate: VertiClip® SL600,s3lg,b2d